

The LED Magic U-Bend is an energy efficient replacement for traditional fluorescent T8 lamps. Designed to operate on all existing instant-start, rapid-start, programmed-start and emergency fixture ballasts...or simply no ballast at all.

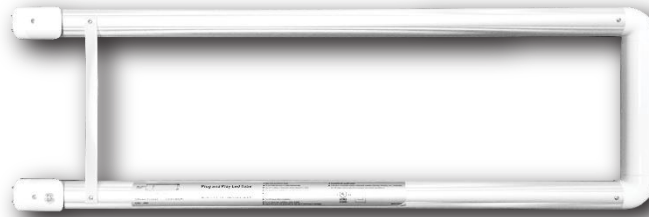

### DIMENSIONS

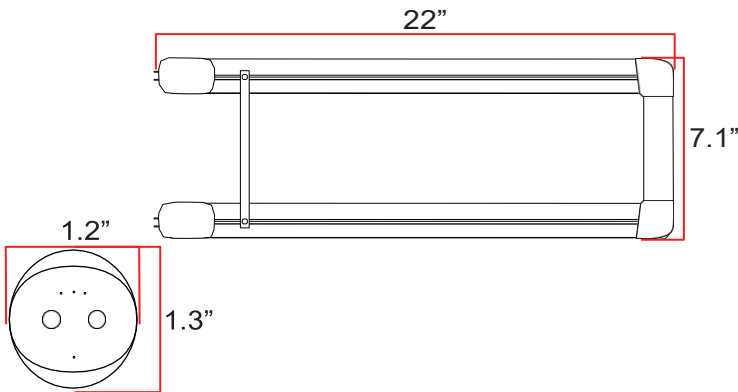

### CERTIFICATIONS



### FEATURES

- Works both with or without a ballast
- Works both with shunted or non-shunted sockets
- Fantastic replacement “plug and play” tube or retrofit kit
- Compatible with over 90% of all North American electronic ballasts
- Versatility supports massive projects with different types of ballasts
- Suitable for damp or dry environments
- Minimize labor and recycling costs
- Stable lumen output for different ballast brands with different ballast factors
- UL Type A & B
- 5 Year Manufacturer’s Warranty

### COMMON TECHNICAL DATA

Color Temperature	3000K-5000K
Beam Angle	120°
CRI	>80
Operation Temperature	14°F to 86°F
Efficiency with ballast	More than 110LPW
Efficiency without ballast	More than 125LPW
Input Voltage with ballast	100-277VAC, 347V
Input Voltage without ballast	100-277VAC
Frequency	50-60Hz
Power Factor	More than 0.90
Rated Life	50,000 hours
LED Type	SMD 2835
Housing	Aluminum/PC

### WARRANTY

This product has a warranty for a period of 5 years from the date of purchase. The warranty is invalid in the case of improper installation, tampering, or removal of the Q.C. date label. Installation in an improper working environment or installation not according to the current edition of the National Electric Code also invalidates the warranty. Should this product fail during the warranty period, it will be replaced free of charge, subject to correct installation and return of the faulty unit. Ecomax does not accept responsibility for any installation costs associated with the replacement of this product. This warranty is in addition to the statutory rights in the country of purchase. Ecomax reserves the right to alter specifications without prior notice.

## PRODUCT SPECIFICATION

Product Number	Length (inch)	Color	Watt	Lumens	Average System Watts (W)			Average System Initial Lumens		
					Low Ballast Factor (0.78)	Norm Ballast Factor (0.88)	High Ballast Factor (1.10)	Low Ballast Factor (0.78)	Norm Ballast Factor (0.88)	High Ballast Factor (1.10)
ZY-T8-15W600U-BIXX	24"	3000K-5000K	15W	1875	16.5	17.5	20.5	2069	2180	2560

## ORDERING GUIDE

ZY	T8	15W	600	U	B	I	XX	3000K-5000K
Company Code	Housing Type	Wattage	Length	Shape	2835 LED	Internal Driver	Input Type	CCT

## INSTALLATION INSTRUCTIONS

### Direct Replacement Procedure:

1. Turn OFF power to the fixture at the breaker panel before installation.
2. Open the diffuser from the light fixture.
3. Remove the fluorescent tubes (A) and dispose of these properly as they may contain mercury.
4. Put LED tube (B) into the lighting fixture and ensure the pins are firmly seated in lampholders.
5. Install the LED tubes and close the diffuser.
6. Switch ON power to the fixture at the breaker panel

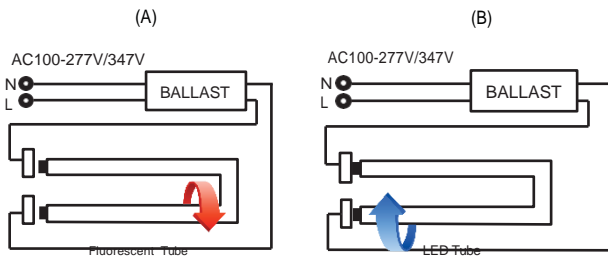

### Retrofit Procedure:

1. Turn OFF power to the fixture at the breaker panel before installation.
2. Open the diffuser from the light fixture.
3. Remove the fluorescent tubes and dispose of these properly as they may contain mercury.
4. Cut wires as shown on diagram (A) below.
5. Make new wire connection to the branch circuit as shown on diagram (B) below.
6. Replace the cover over the wiring channel.
7. Install the LED tubes and close the diffuser.
8. Switch ON power to the fixture at the breaker panel

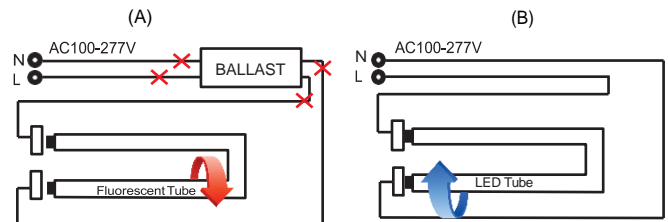

## CAUTION

- Risk of fire- do not install this lamp in a pre-heated luminaire.
- Loose or damaged end caps and/or lamp holders need to be replaced before installation.
- Risk of electric shock- make installation with gloves.
- Use only in place of fluorescent lamps specified on label.
- These lamps are intended for use with emergency exists.
- These lamps are to be used with a light dimmer.
- If the lamp or luminaire exhibits undesirable operation (i.e. buzzing, flickering, etc.), immediately turn off power and remove the lamp from luminaire and contact manufacturer.
- This lamp only operates on electronic ballasts. If lamp does not light when the luminaire is energized, remove this lamp from luminaire and contact manufacturer.
- Check the ballast installed in the field and make sure the ballast is in manufacturer's ballast list. If the ballast out of the list, a test must be needed before mass installation.
- Do not make mass installation before sample testing.