

STEU1



ILLUMINATION

- Long lasting, efficient ultra bright white LED lamp heads. 1.5 Watt (12 LEDs*0.125W) per head.
- High performance chrome-plated metallized reflector and plastic lens for optimal light distribution.
- Adjustable LED lamp heads provides optimal center-to-center spacing.
- Optional high-lumen heads are available for increased center-to-center spacing.
- Long life, energy efficient.
- Overload/Short Circuit Protection
- Test Switch/Power Indicator Light

ELECTRICAL

- Dual 120/277 voltage.
- Charge rate/power "ON" LED indicator light and push-to -test. switch for mandated code compliance testing.
- 6V Long life, maintenance-free, rechargeable Ni-Cd battery.
- Internal solid-state transfer switch automatically connects the internal battery to LED board and LED lamp heads for minimum 90-minute emergency illumination.
- Fully automatic solid-state, two rate charge initiates battery charging to recharge a discharged battery in 24 hours. Remote capacity option available.

DIMENSIONS

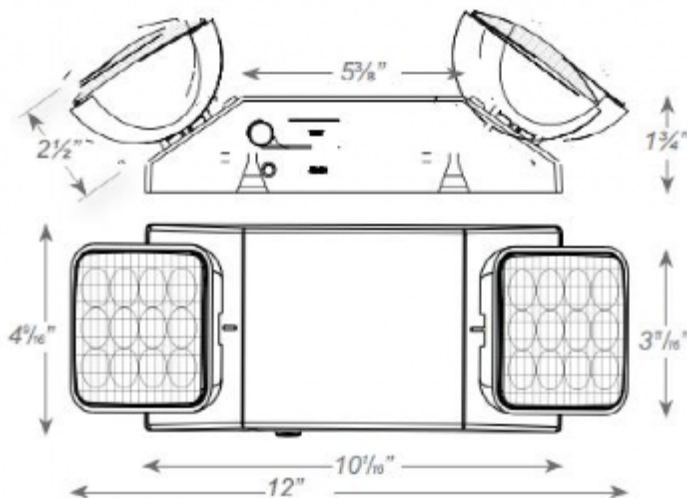

MOUNTING

- EZ-snap mounting canopy included for top or end mount.
- Universal K/O pattern on back plate for wall mount.

HOUSING

- Injection-molded, engineering grade. 5VA flame retardant, high-impact resistant, thermoplastic in white or black finish.
- EZ snap-out chevron directional indicators.

WARRANTY / LISTING

- Five year warranty on all electronics and housing. - Battery pro-rated for three years.
- meets UL 924
- cULus Listed for damp location(0 °C-50 °C)
- Life Safety NFPA 101
- NEC/OSHA
- Most State and Local Codes

