

## 200W LED SHOEBOX AREA LIGHT

### Product Features

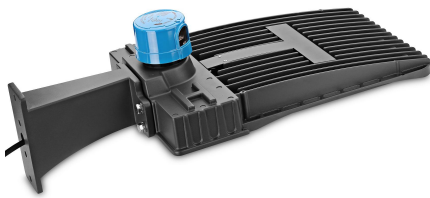

- High efficiency LED Driver, the wide range input voltage AC120-277V or AC277-480V;
- Lumileds LED high luminous efficiency and long life.
- Cast aluminium design, better cooling and easy replacement, light quality, LED Tj < 85°C.
- Excellent optical design, greatly improve the light utilization and evenness.
- **Photocell Control and Motion Sensor Available (Option)**

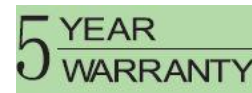

### Product Applications

ECOMAX SHOEBOX AREA LIGHT series can be widely used in Urban roads, Industrial areas, Residential areas, Sidewalks, Parking lot, Schools, Gardens and etc.

### Structure Features

- **Shell materials:** Aluminum & PC.
- **Finish:** Dark Bronze/White
- **Net weight:** 16.60 lbs
- **Packing Size:** 26 " \* 13.8 " \* 7.3 "

Unit: inch

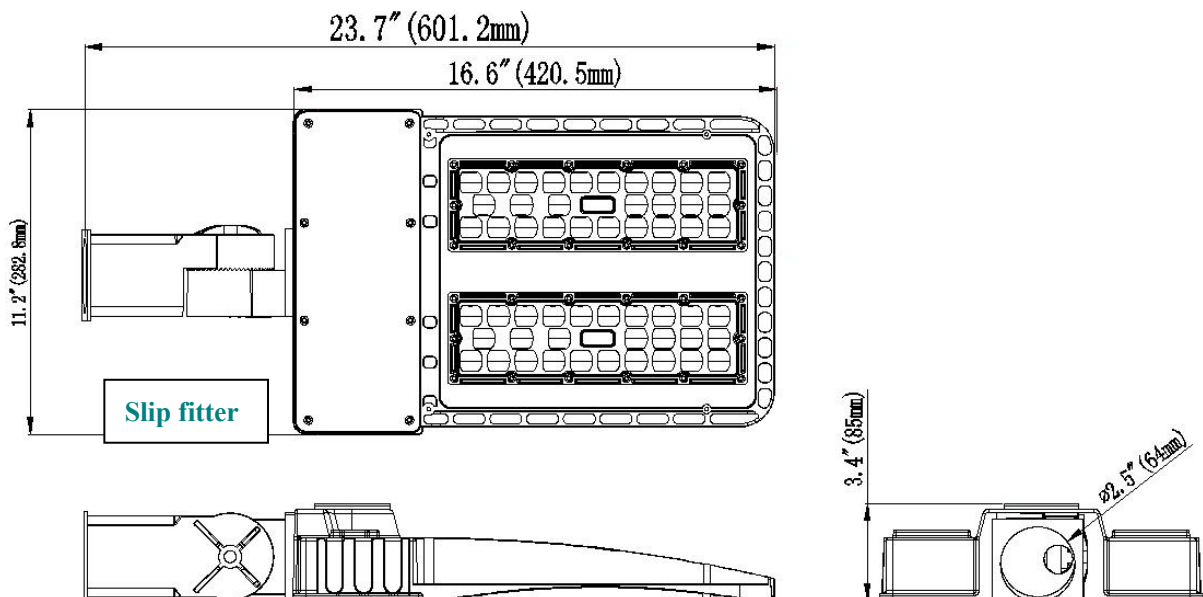

### ■ Technical Parameters

Type	WSD-SB20W27-XXK-Z-TN-U-Y WSD-SB20W48-XXK-Z-TN-U-Y		
Power	200W	Lighting Angle	Type II, Type III, Type IV, Type V
Input Voltage	AC120-277V AC277-480V	LED Brightness Decay	<5%/6000 hrs
PF	>0.95	Working Life	>50000 hrs
Driver Efficiency	>90%	Working Temperature	-22F - +113F
Luminous Flux	22400Lm	Storage Temperature	-40F - +176F
Color Temperature	3000K/4000K/5000K/5700K	Protection Level	Wet Location/IP65
CRI	Ra>80	Cable	3 core, 18AWG

### ■ Photometry and Type V:

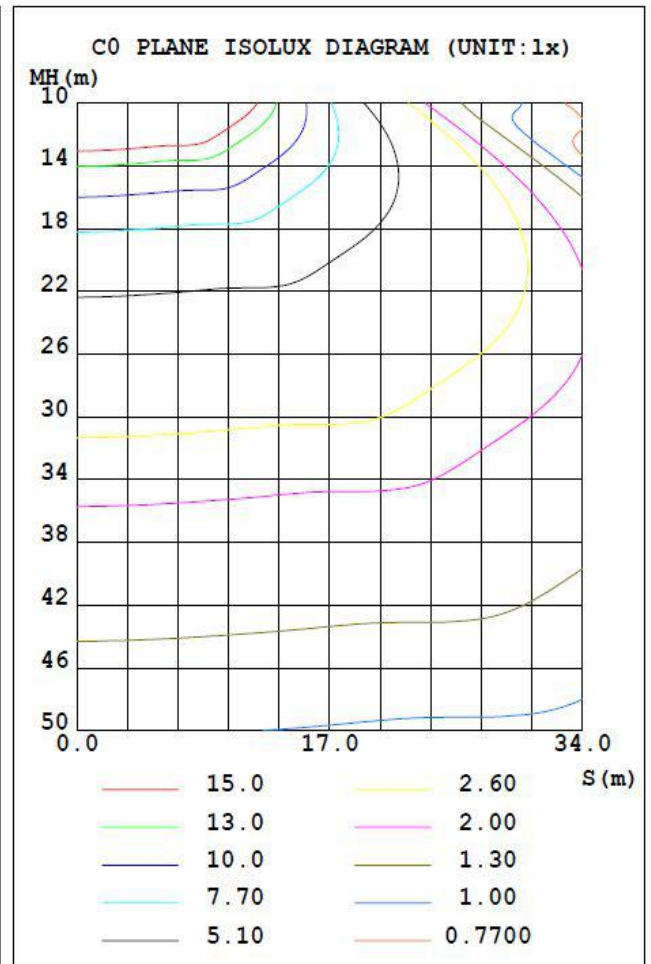
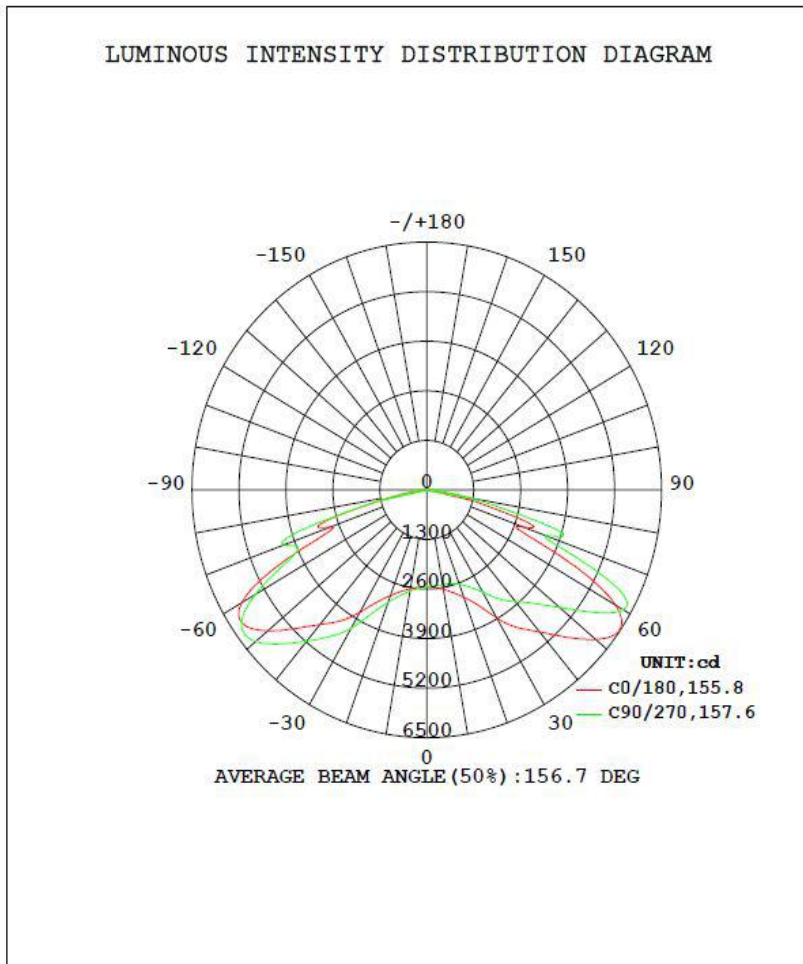

#### ■ Accessory Option:

##### II T: TRUNNION MOUNTING

Dimensions of the trunnion

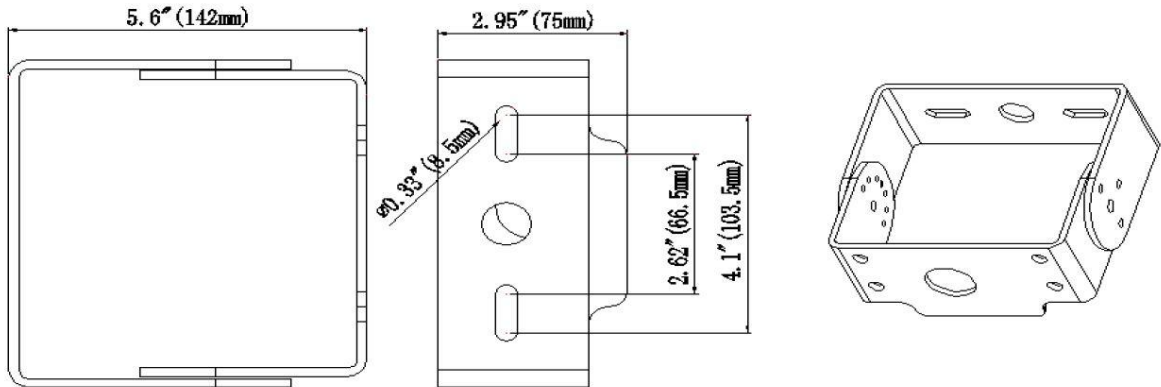

##### III A1: ARM MOUNTING FOR SQUARE POLE

Arm dimensions

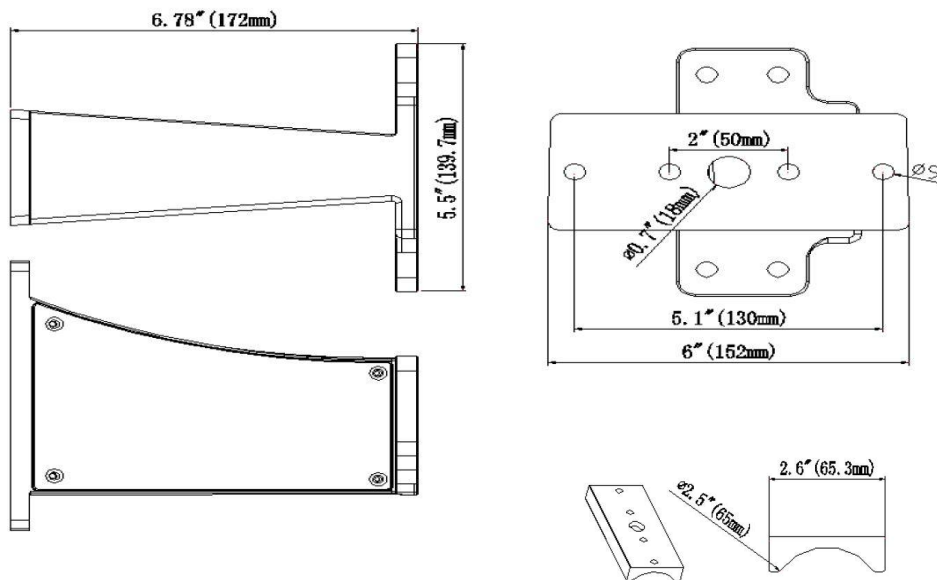

#### ■ ARM Adaptor for Round Pole:

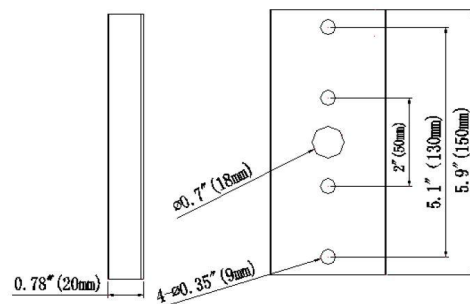

#### ● ORDERING INFORMATION:

**EXAMPLE: WSD-SB 20W 27-40K-D-T5-S-P**

WSD	SB	10W	27	50K	D	T5	S	P
Co.Code	Product	Power	Voltage	Color Temp	Finish	IES	Mount	Control
	SB SHOEBOX LIGHT	06W(60W) 10W(100W) 15W(150W) 20W(200W) 30W(300W)	27 AC120-277V 48 AC200-480V	40K (4000K) 50K (5000K) 57K (5700K) ± 500K	D Dark Bronze W White B Black	T2 TypeII T3 TypeIII T4 TypIV T5 TypeV	S Slip fitter T Trunnion A Arm	P 120-277V Photocell 10V Dimming1-10V M Motion Sensor

While “XX” may be any digits represented color temperature;  
 “Z” may be D or W represented color,  
 “N” can be 2, 3 or 5 represented type of lighting distribution;  
 “U” can be S, A or T mounting.  
 “Y” may be “P” or blank represented type of photoelectric Switches  
 “10V” be dimming 1-10V Control  
 “M” be Motion Sensor Control.

#### ■ Product Certifications

