

■ Product Pictures



- Philips Lumileds LED, high luminous efficiency and long working life.
- High efficiency LED Driver, the wide range input voltage AC100-277V.
- Cast aluminium cooling design better cooling, better cooling, light quality, LED Tj < 85°C.
- Excellent Optics design, greatly improve the light utilization and evenness.
- **Photocell Control Available (Option)**

PHILIPS
LUMILEDS

5 YEAR
WARRANTY



■ Product Applications

ECOMAXLED WALL PACK Lighting series can be widely used in indoor or outdoor lighting (Wet location) , like mechanical or electronic processing workshops, storage warehouses, steel mills, gas stations, toll booth, waiting rooms, the platforms of railway station , indoor stadiums and flower cultivating tents etc.

■ Structure Features

- **Shell materials: Aluminum & PC**
- **Color: Dark Bronze**
- **Net weight: 7.7lbs** Unit: in
- **Packing Size: 15.7x10.2x9.0in**

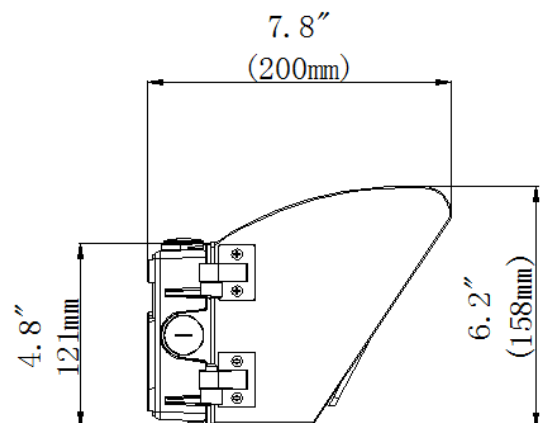
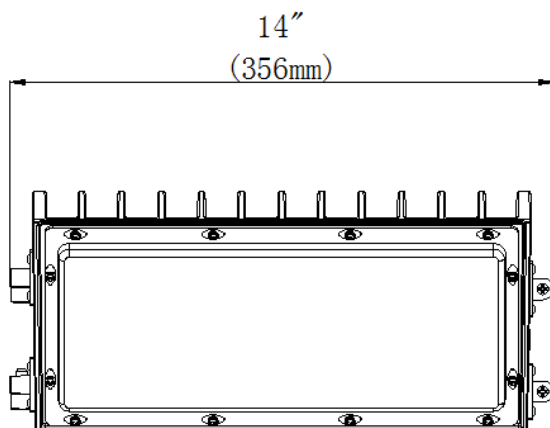

■ Technical Parameters

Type	WSD-HWP07W27-50K		
Power	70W	Lighting Angle	60*90°
Input Voltage	AC100-277V	LED Brightness Decay	<5%/6000 hrs
PF	>0.95	Working Life	>50000 hrs
Driver Efficiency	>90%	Working Temperature	-22F - +113F
Luminous Flux	6770 Lm	Storage Temperature	-40F - +176F
Color Temperature	5000K	Protection Level	Wet Location/IP65
CRI	Ra>80	Cable	Input Connect, No cable

■ Light Distribution Curve (Clear Lens)

