

Product Pictures

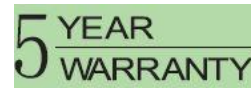

- Lumileds LED, high luminous efficiency and long working life.
- High efficiency LED Driver, the wide range input voltage AC100-277V and AC200-480V.
- Cast aluminium cooling design better cooling, better cooling, light quality, LED Tj < 85°C.
- Excellent Optics design, greatly improve the light utilization and evenness.
- **Photocell Control Available (Option)**



Product Applications

ECOMAX LED FULL CUTOFF WALL PACK Lighting series can be widely used in indoor or outdoor lighting (Wet location), like mechanical or electronic processing workshops, storage warehouses, steel mills, gas stations, toll booth, waiting rooms, the platforms of railway station, indoor stadiums and flower cultivating tents etc.

Structure Features

- **Shell materials: Aluminum & PC .**
- **Finish: Dark Bronze**
- **Net weight: 6.6lbs**

Unit: inch(mm)

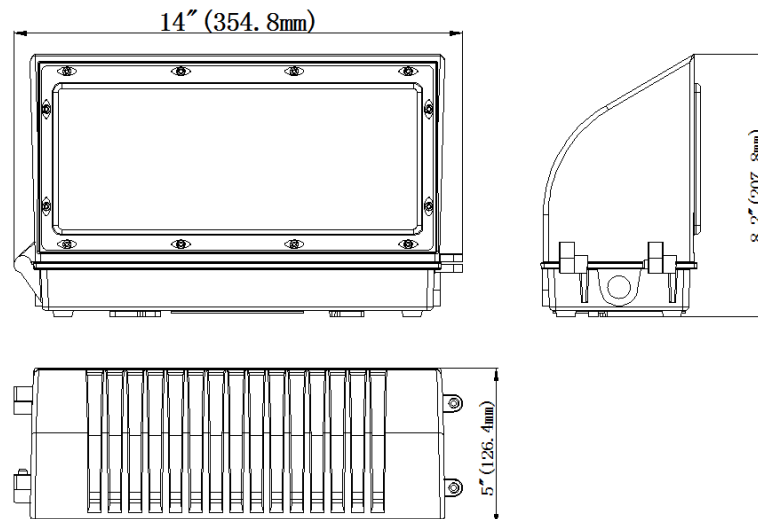

■ Technical Parameters

Type	WSD-FWP07W27-50K		
Power	70W	Lighting Angle	60*90°
Input Voltage	AC100-277V	LED Brightness Decay	<5%/6000 hrs
PF	>0.95	Working Life	>50000 hrs
Driver Efficiency	>90%	Working Temperature	-22F - +113F
Luminous Flux	7200 Lm	Storage Temperature	-40F - +176F
Color Temperature	5000K	Protection Level	Wet Location/IP65
CRI	Ra>80	Cable	Input Connect, No cable

■ Light Distribution Curve (Clear Lens)

