

Product Descriptions

INTENDED Purchase — The LED Corn bulbs is light for replace traditional 360 degree lights such as metal halide,CFL,HID,HPS for parking lot,gas station,warehouse indoor and outdoor energy saving purpose.Design install into existing fixture with cost-effective solution.

STRUCTURE — Die casting aluminum no fan passive cooling solution,PC cover protect LEDs from dust,insect and humidity working environment.Driver fully sealed by thermal paste with function to disperse heat into outside.Adopt 150LM/W LED chips improve light efficiency.Driver part apart from lamp body speed cooling hot air out.

OPTICS —Milky and Transparent PC cover for choice range from 27W~125W with E26,E27,E39,E40 socket for choice in different application sealed or open fixture.

ELECTRICAL — Standard 6kV surge protection,regular input voltage 100~277V,no ballast need.

INSTALLATION — Easily fitted in traditional fixture instead of MHL and HPS.

LISTINGS — UL,cUL,DLC certification approved.
Suitable for sealed,dry,humidity working environment from -40 C up to 45 C

WARRANTY — 5 years warranty.
Replaceable driver part design.Free provide materials replacement easy for customer replace.
We will responsible if damaged or quality problem. like damaged under shipment.
Screws loosen.Driver problem.

Model: NG-RCL-54W



Features

E26 E27 E39 E40(27~54W)
E39 E40(80~125W)
UL,cUL,DLC approved
360° Degree Beam Angle
100~277V input voltage
No fan Passive cooling solution
Die-casting heat sink
Suitable in enclosed fixture
PC Cover milky&transparent
Driver fully sealed by thermal paste.
6K High voltage Surge test approved.

SMD2835 150Lm/W LED chips
50,000hrs lifespan
5 years warranty
Top Brand Rubycon Capacitors
No UV or IR radiation
No magnetic disturbance driver design
OEM special design company LOGO
IP64 waterproof dust free
Separately driver with body speed heat dissipation(80~125W)
Net weight: 0.936kg
Package size: 610*303*490cm(carton)(20 pieces)
Package size: 110*110*130mm(EPE)(1 pieces)

Series	Lumens	Base	Beam Angle (Degree)	Electrical Data	No.of LEDs	Color temperature	Color rendering index
NG-RCL-54W	7900LM 7,900 lumens	E26,E27,E39,E40	360° Degree Beam Angle	Input Voltage 100-277V 50~60Hz Total Power(W) 54W Power Factor(%) >90	429PCS SMD2835 chips	WW 2800~3200 K NW 4000~4500 K DW 5000~5500 K CW 6000~6500 K	70 70 CRI 80 80 CRI 90 90 CRI

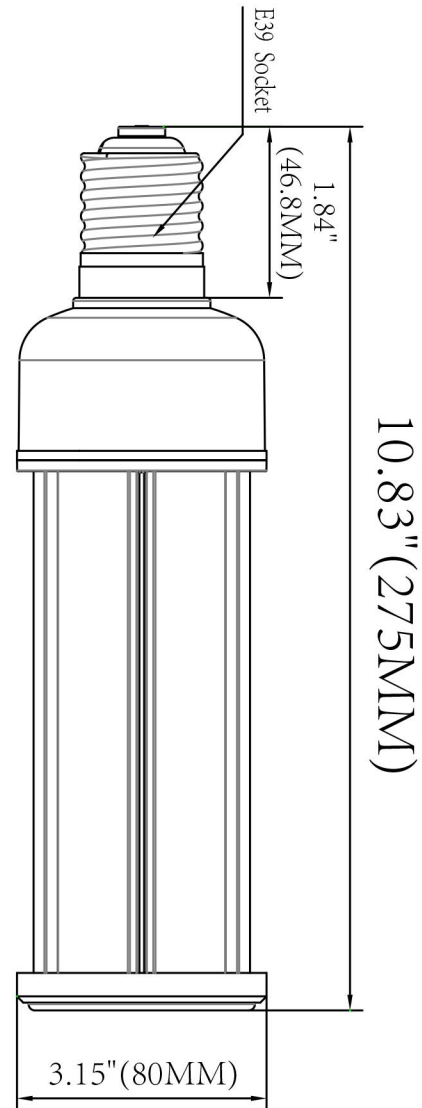
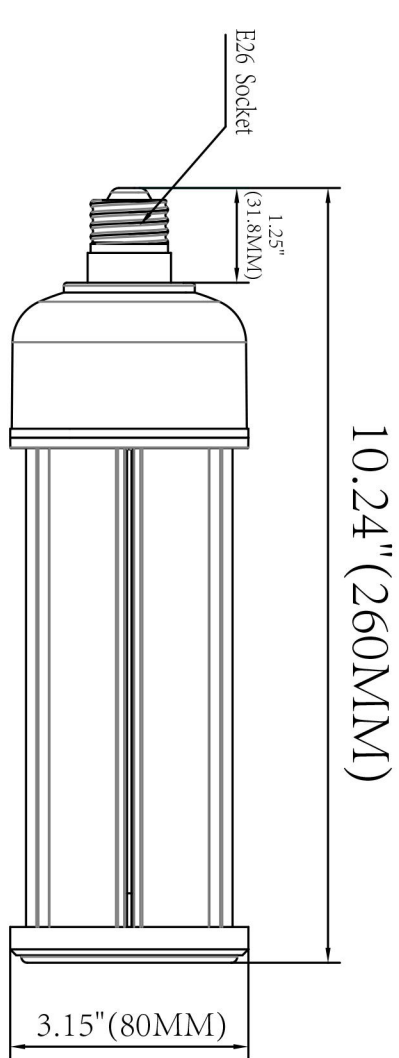

Light Source Test Report

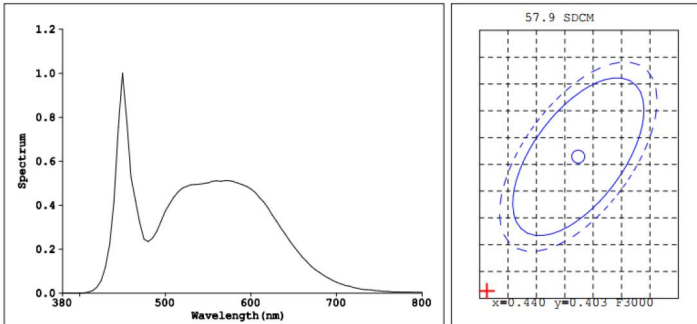

Color Parameters:

Chromaticity Coordinate: $x=0.3281$ ($dx=-0.0002$) $y=0.3504$ ($dy=0.0129$)
 Chromaticity Coordinate: $u'=0.2004$ $v'=0.4816$ ($duv=6.67e-03$)
 Tc=5687K Dominant WL:Ld=535.4nm Purity=3.8% Centroid WL:546.0nm
 Ratio:R=15.4% G=80.0% B=4.6% Peak WL:Lp=450.0nm HWL:20.0nm
 Render Index:Ra=82.7

R1 =80 R2 =87 R3 =93 R4 =83 R5 =81 R6 =83 R7 =88
 R8 =67 R9 =2 R10=70 R11=82 R12=59 R13=82 R14=96 R15=74

Photo Parameters:

Flux: 7871 lm Fe: 23.152 W Efficacy:146.3 lm/W
 WHITE:ANSI_5700K

Electrical Parameters:

Lamp : U=223.7V I=0.2280A P=53.8W PF=0.9800

Instrument Status:

Scan Range:380.0nm-800.0nm Interval:5.0nm[0] Ip=13246(G=3,D=54)
 REF=14279(R=3) $\#=0.741\%$ PMT: 27.0 centigrade [26.7]

REPLACE CFL

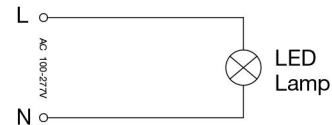

REPLACE HPS

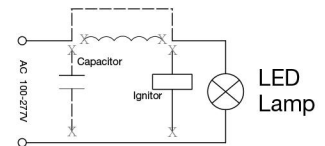
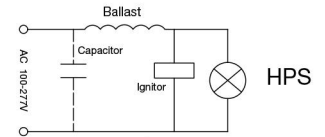

1. Remove old ballast or disconnect from existing lamp holder.
Remove and dispose of ballast in correct manner.
Shown as Figure 1.(North America 100-277 VAC)

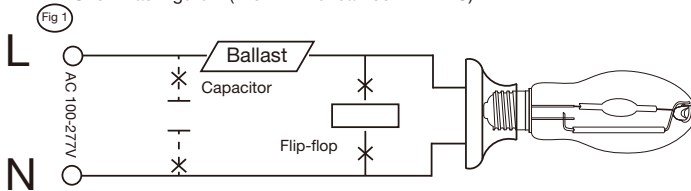

Fig 2

2. Reconnect directly to the existing lamp holder. Shown as Figure 2
(North America 100-277VAC)

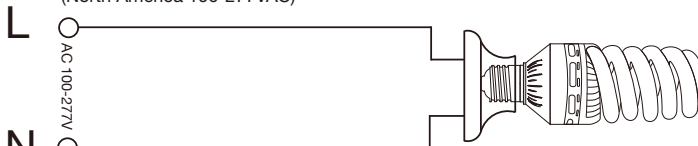
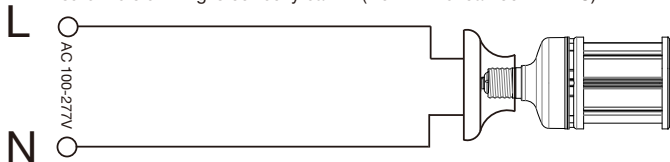
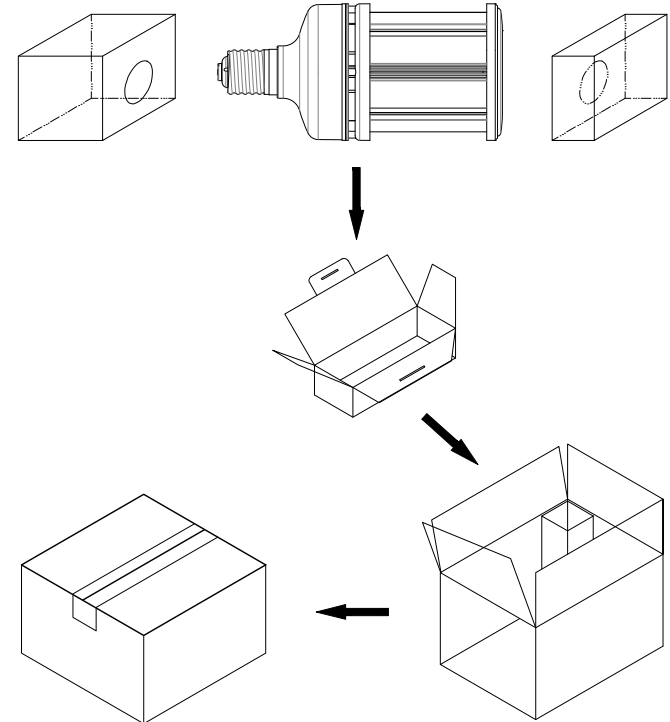

Fig 3

3. Install New LED Replacement lamp. Shown as Figure 3. Please make sure the old fitting is correctly earth. (North America 100-277VAC)



INSTALLATION



PACKAGING