

NGWL-50W9S

- E26, E27, E39, E40 socket available.
- 125~135Lm/W light effi.
- Aluminum PCB with heatsink design cooling fast.
- Replace MH, CFL, HPS, HID, incandescent, mercury.
- Application in Warehouse, Garden, House, park, street, commercial lighting, etc.



Electrical data

Rated wattage	50W
Input Voltage	AC100-277V
Operating frequency	50/60 Hz
Rated power factor λ	>0.9
Power Efficiency	>0.95
Ambient temperature	-45~45 °C
Protection grade	IP40
Material	PBT+Aluminum
Gross weight	0.50kgs
Net weight	0.45kgs

Light technical data

Beam angle	360 degree
Light Source	400pcs SMD2835
Luminous flux	6575.20lm
Warm White:	2,800 ~ 3,200 K
Natural White:	4,000 ~ 4500 K
Day Light:	5,000 ~ 5,500K
Cool White:	6,000 ~ 6,500K
PC Cover:	Milky/Transparent
Color rendering index Ra:	Ra>80
Lifespan:	50,000hrs

DIMENSIONS

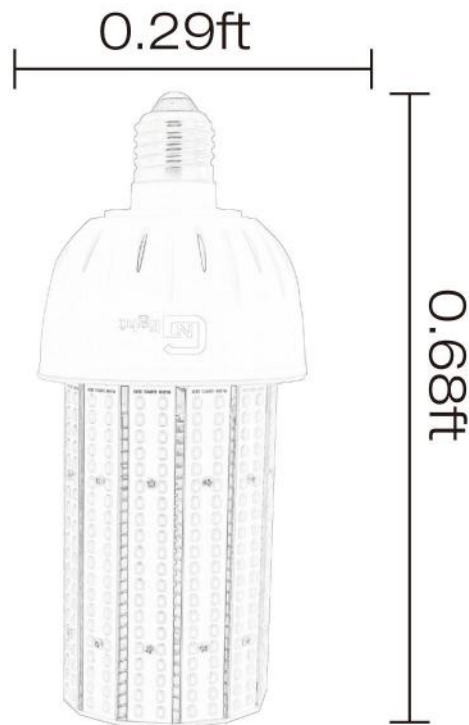
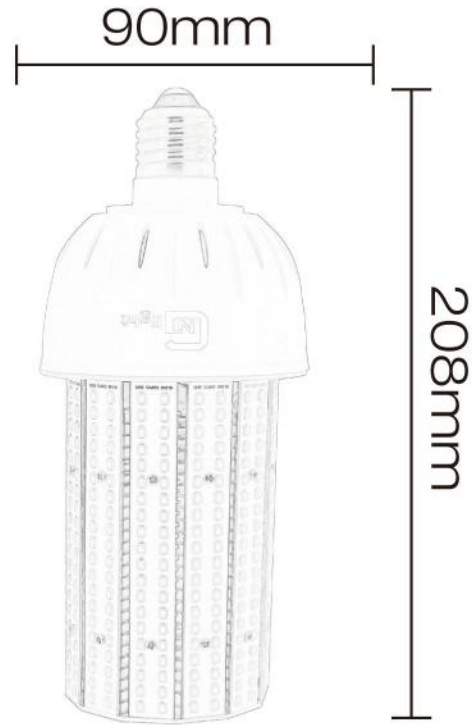
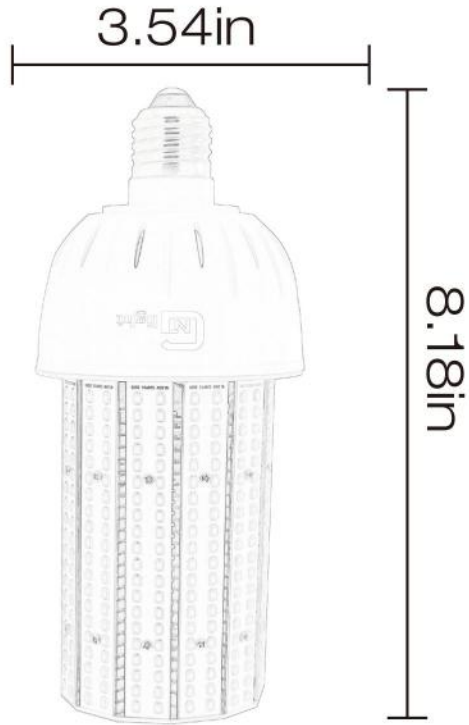

50W LED Corn Light

Product Mark

Product Type :50W LED Corn Light

Temperature :25'C

Operator :admin

Remark:

Manufacturer :

Humidity :65%

Test Date :2014-09-03 17:00:50

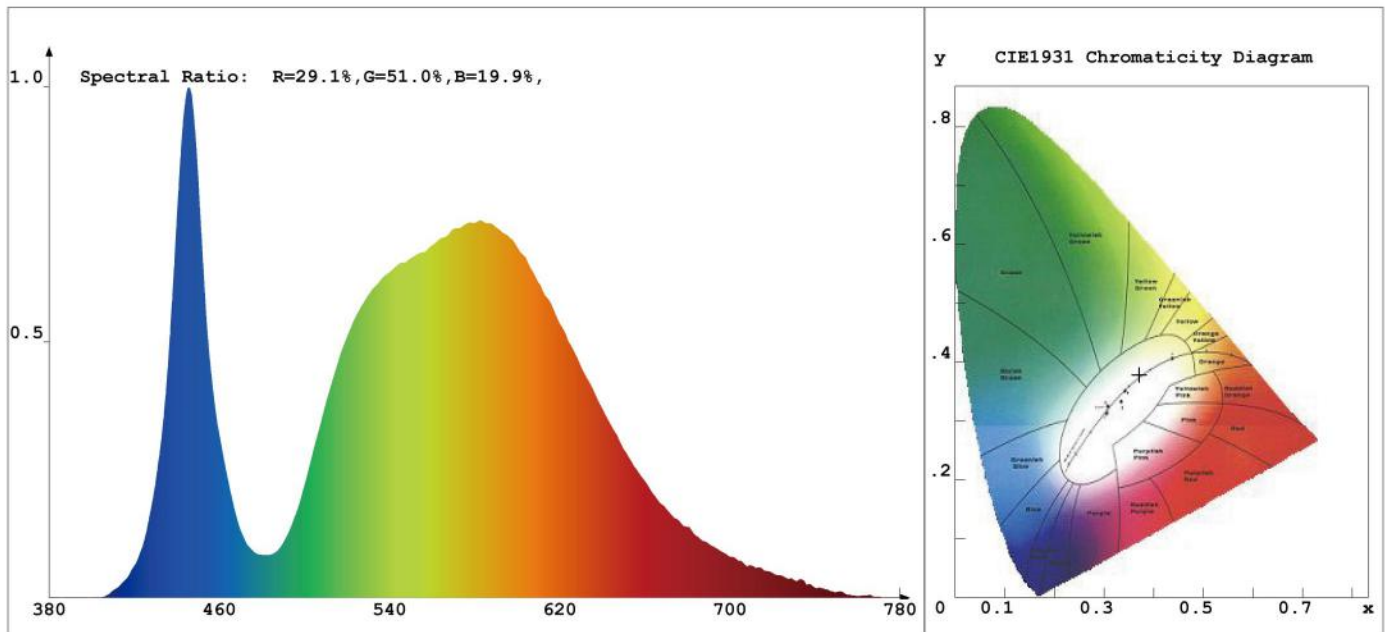

Chroma Parameters

Chro.Coor.:x=0.3710 y=0.3789 u=0.2181 v=0.3341 duv=0.0039

CCT: 4280K Dominant Wave.:575.7nm Purity:25.1%

Flux RGB Ratio:R=15.7%,G=82.7%,B=1.6% Peak Wave:445.6nm Half Width:17.8nm

Rendering Index:Ra= 71.1

R1 =68	R2 =76	R3 =82	R4 =72	R5 =68	R6 =67	R7 =81	R8 =54
R9 =0	R10=43	R11=69	R12=39	R13=69	R14=90	R15=62	

Photo Parameters

Flux:6575.20lm Effi.:134.0lm/W Radiant:16227.5mW Ri:0.0mW/sr

Ele. Parameters

Voltage:U=220.400V

Current:I=0.2290A

Power:P=48.82W

Power Factor:PF=0.963

Instrument state

Instrument:Hopoo HP8000S

Integral Time: 2.904ms

VPeak: 10432

VDark: 1255

Scan Range: 380-780nm

Product ID: 201308416

INSTALLATION

1. Remove old ballast or disconnect from existing lamp holder.
Remove and dispose of ballast in correct manner.
Shown as Figure 1. (North America 100-277 VAC)

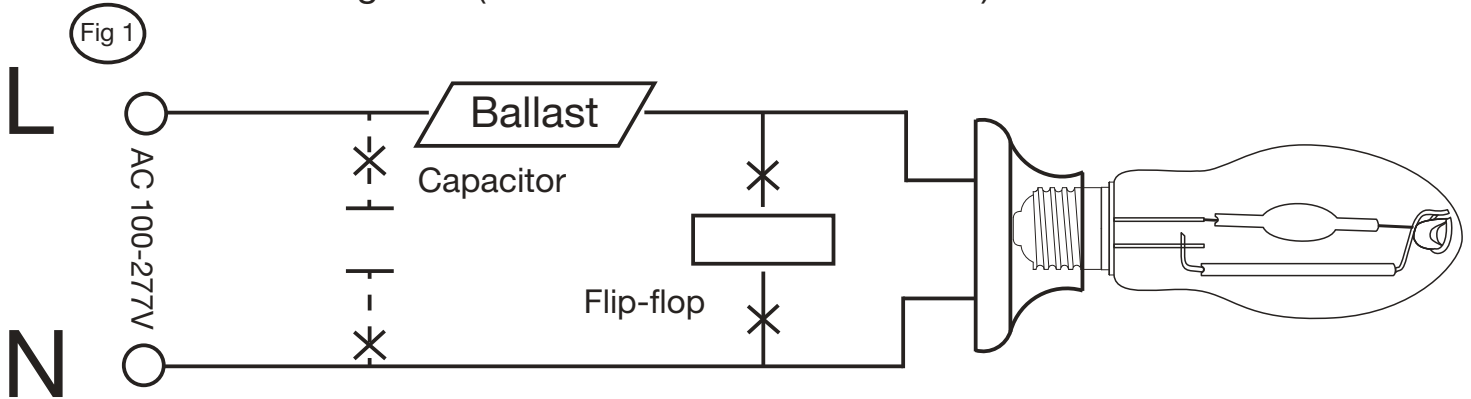

Fig 2

2. Reconnect directly to the existing lamp holder. Shown as Figure 2
(North America 100-277VAC)

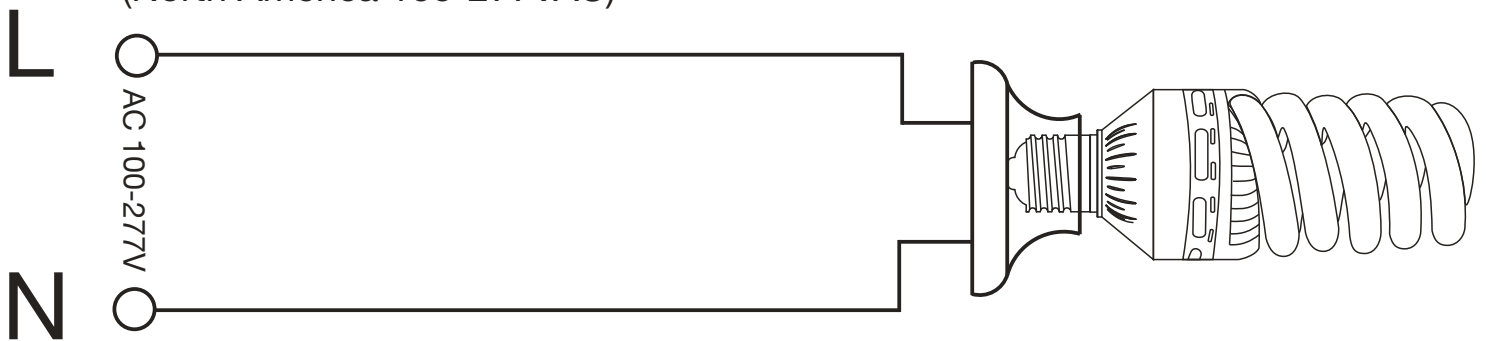

Fig 3

3. Install New LED Replacement lamp. Shown as Figure 3. Please make sure the old fitting is correctly earth. (North America 100-277VAC)

